



Product Preview

OCTAL TRANSCEIVER/REGISTER WITH 3-STATE OUTPUTS

These devices consist of bus transceiver circuits with 3-state D-type flip-flops, and control circuitry arranged for multiplexed transmission of data directly from the input bus or from the internal registers. Data on the A or B bus will be clocked into the registers as the appropriate clock pin goes to a high logic level. Output Enable (OE) and DIR pins are provided to control the transceiver function. In the transceiver mode, data present at the high impedance port may be stored in either the A or the B register or in both. The select controls can multiplex stored and real-time (transparent mode) data. The direction control determines which bus will receive data when the enable OE is Active LOW. In the isolation mode (OE HIGH), A data may be stored in the B register and/or B data may be stored in the A register.

- Independent Registers for A and B
- Multiplexed Real-Time and Stored Data
- Choice of True (F646) and Inverting (F648) Data Paths
- 3-State Outputs

PIN ASSIGNMENTS

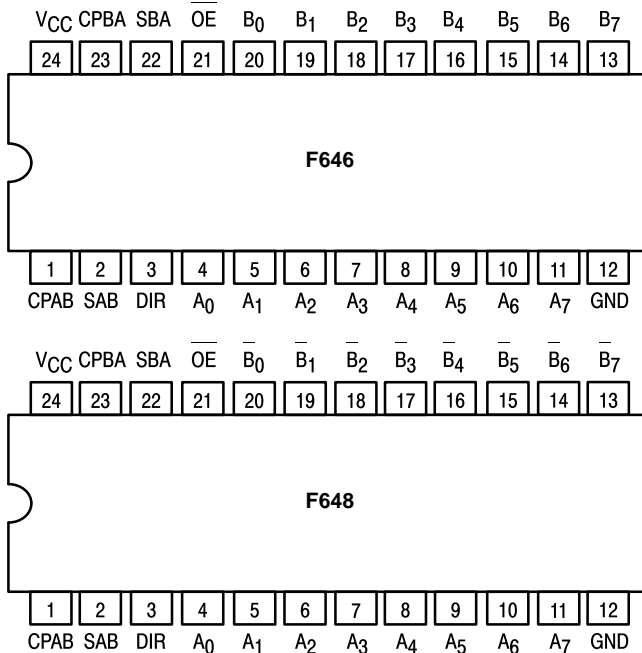

LOGIC SYMBOLS

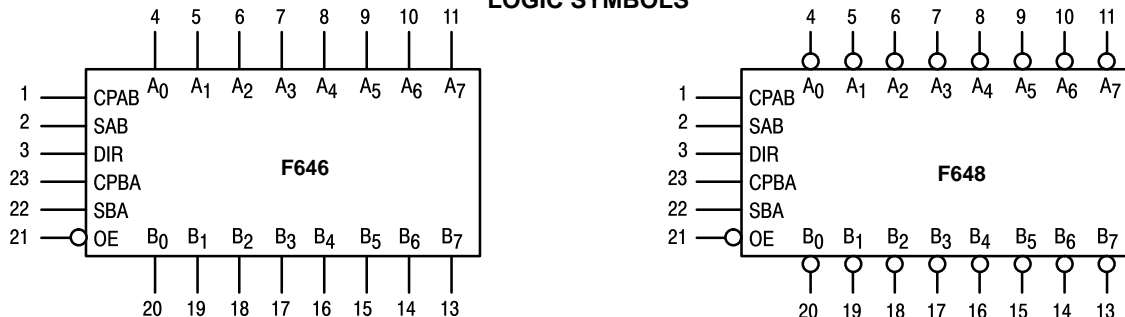

This document contains information on a product under development. Motorola reserves the right to change or discontinue this product without notice.

MC54/74F646
MC54/74F648

OCTAL TRANSCEIVER/REGISTER WITH 3-STATE OUTPUTS

FAST™ SCHOTTKY TTL

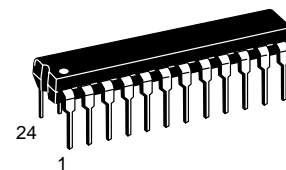

J SUFFIX
CERAMIC
CASE 758-01

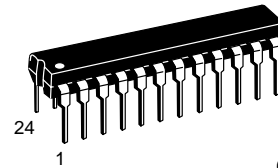

N SUFFIX
PLASTIC
CASE 724-03

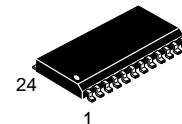

DW SUFFIX
SOIC
CASE 751E-03

ORDERING INFORMATION

MC54FXXXJ Ceramic
MC74FXXXN Plastic
MC74FXXXDW SOIC

MC54/74F646 • MC54/74F648

FUNCTION TABLE

Inputs						Data I/O*		Operation/Function
OE bar	DIR	CPAB	CPBA	SAB	SBA	A ₀ –A ₇	B ₀ –B ₇	
H	X	H or L	H or L	X	X	Input	Input	Isolation
H	X	↑	X	X	X	Input	Input	Store A _n Data in A Register
H	X	X	↑	X	X	Input	Input	Store B _n Data in B Register
H	X	↑	↑	X	X	Input	Input	Store A _n /B _n Data in A/B Register
L	H	X	X	L	X	Input	Output	A _n to B _n — Real Time (Transparent Mode)
L	H	↑	X	L	X	Input	Output	Store A _n Data in A Register
L	H	H or L	X	H	X	Input	Output	A Register to B _n (Stored Mode)
L	H	↑	X	H	X	Input	Output	Clock A _n Data to B _n and into A Register
L	L	X	X	X	L	Output	Input	B _n to A _n — Real Time (Transparent Mode)
L	L	X	↑	X	L	Output	Input	Store B _n Data in B Register
L	L	X	H or L	X	H	Output	Input	B Register to A _n (Stored Mode)
L	L	X	↑	X	H	Output	Input	Clock A _n Data to B _n and into B Register

*The data output function may be enabled or disabled by various signals at the OE bar and DIR inputs. Data input functions are always enabled; i.e., data at the bus pins will be stored on every low-to-high transition of the appropriate clock inputs.

H = HIGH voltage level
 L = LOW voltage level
 X = Don't Care
 ↑ = Low-to-High transition

GUARANTEED OPERATING RANGES

Symbol	Parameter		Min	Typ	Max	Unit
V _{CC}	DC Supply Voltage	54, 74	4.5	5.0	5.5	V
T _A	Operating Ambient Temperature Range	54 74	-55 0	25 25	125 70	°C
I _{OH}	Output Current — High	54 74	— —	— —	-12 -15	mA
I _{OL}	Output Current — Low	54 74	— —	— —	48 64	mA

MC54/74F646 • MC54/74F648

LOGIC DIAGRAM
F646

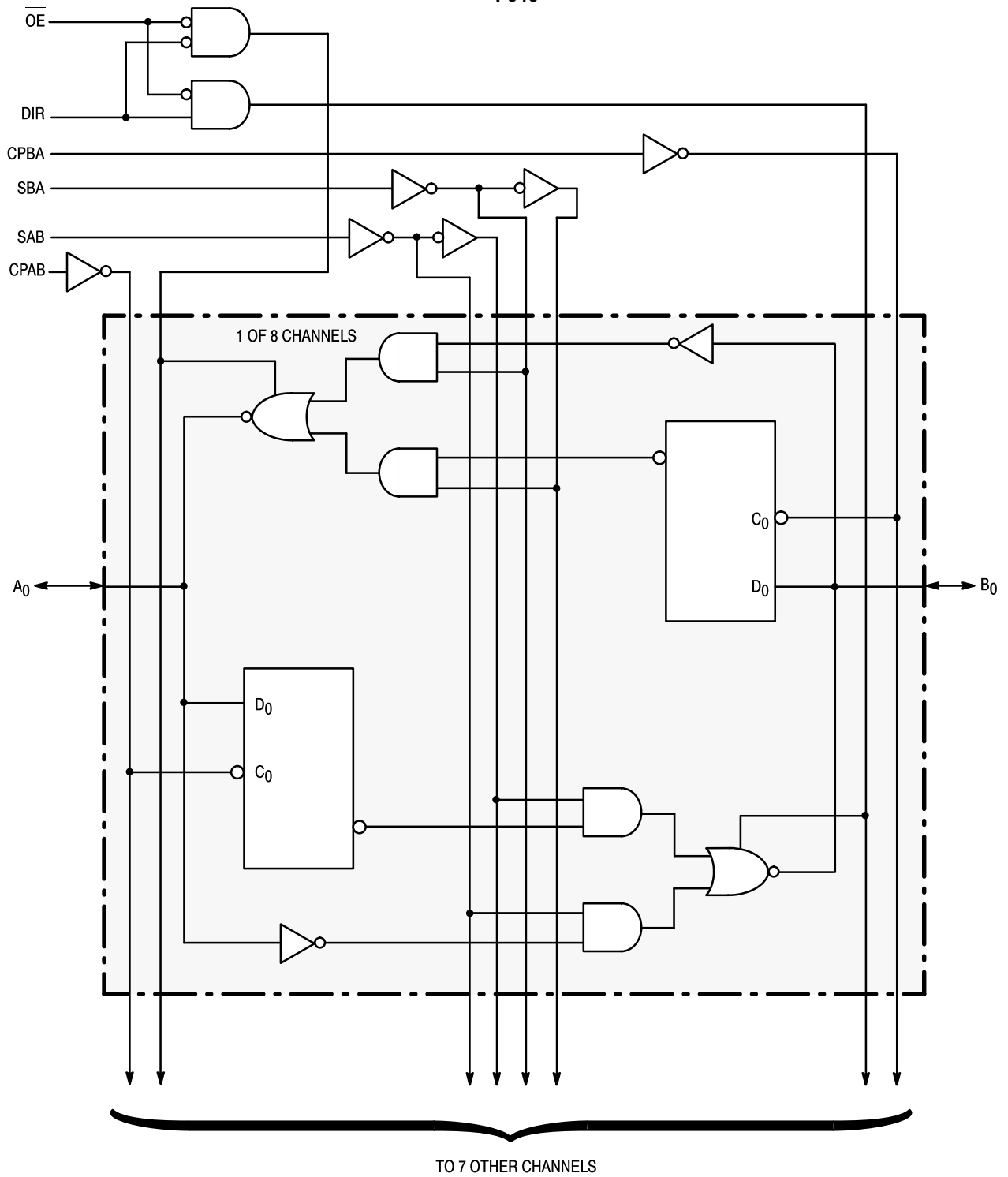

MC54/74F646 • MC54/74F648

DC CHARACTERISTICS OVER OPERATING TEMPERATURE RANGE (unless otherwise specified)

Symbol	Parameter		Limits			Unit	Test Conditions (Note 1)		
			Min	Typ	Max				
V _{IH}	Input HIGH Voltage		2.0	—	—	V	Guaranteed as a HIGH Signal		
V _{IL}	Input LOW Voltage		—	—	0.8	V	Guaranteed as a LOW Signal		
V _{IK}	Input Clamp Diode Voltage		—	—	-1.2	V	V _{CC} = MIN, I _{IN} = -18 mA		
V _{OH}	Output HIGH Voltage	A _n , B _n	54/74	2.4	—	—	V	I _{OH} = -3.0 mA	V _{CC} = 4.5 V
			74	2.7	—	—	V	I _{OH} = -3.0 mA	V _{CC} = 4.75 V
			54	2.0	—	—	V	I _{OH} = -12.0 mA	V _{CC} = 4.5 V
			74	2.0	—	—	V	I _{OH} = -15.0 mA	V _{CC} = 4.5 V
V _{OL}	Output LOW Voltage	A _n , B _n	54	—	—	0.55	V	I _{OL} = 48 mA	V _{CC} = MIN
			74	—	—	0.55	V	I _{OL} = 64 mA	V _{CC} = MIN
I _{IH}	Input HIGH Current		Non I/O Pins	—	—	20	μA	V _{CC} = MAX, V _{IN} = 2.7 V	
			Non I/O Pins	—	—	100	μA	V _{CC} = MAX, V _{IN} = 7.0 V	
			I/O (A _a , B _n)	—	—	1.0	mA	V _{CC} = MAX, V _{IN} = 5.5 V	
I _{IL}	Input LOW Current		Non I/O Pins	—	—	-600	μA	V _{CC} = MAX, V _{IN} = 0.5 V	
I _{IH} + I _{OZH}	Output Leakage Current		I/O (A _n , B _n)	—	—	70	μA	V _{CC} = MAX, V _{OUT} = 2.7 V	
I _{IL} + I _{OZL}	Output Leakage Current		I/O (A _n , B _n)	—	—	-650	μA	V _{CC} = MAX, V _{OUT} = 0.5 V	
I _{OS}	Output Short Circuit Current (Note 2)		-100	—	-225	mA	V _{CC} = MAX, V _{OUT} = GND		
I _{CC}	Power Supply Current		I _{CC} H	—	—	135	mA	V _{out} = HIGH	V _{CC} = MAX
			I _{CC} L	—	—	150		V _{out} = LOW	
			I _{CC} Z	—	—	150		V _{out} = HIGH Z	

NOTES:

1. For conditions shown as MIN or MAX, use the appropriate value specified under recommended operating conditions for the applicable device type.
2. Not more than one output should be shorted at a time, nor for more than 1 second.

MC54/74F646 • MC54/74F648

AC ELECTRICAL CHARACTERISTICS

Symbol	Parameter	54/74F		54F		74F		Unit
		$T_A = +25^\circ\text{C}$ $V_{CC} = +5.0\text{ V}$ $C_L = 50\text{ pF}$ $R_L = 500\ \Omega$		$T_A = -55^\circ\text{C to } +125^\circ\text{C}$ $V_{CC} = +5.0\text{ V } \pm 10\%$ $C_L = 50\text{ pF}$ $R_L = 500\ \Omega$		$T_A = 0^\circ\text{C to } +70^\circ\text{C}$ $V_{CC} = +5.0\text{ V } \pm 10\%$ $C_L = 50\text{ pF}$ $R_L = 500\ \Omega$		
		Min	Max	Min	Max	Min	Max	
f_{MAX}	Maximum Clock Frequency	100	—	75	—	90	—	MHz
t_{PLH} t_{PHL}	Propagation Delay Clock to Bus	2.0 2.0	7.0 8.0	2.0 2.0	8.5 9.5	2.0 2.0	8.0 9.0	ns
t_{PLH} t_{PHL}	Propagation Delay Bus to Bus (F646)	1.0 1.0	7.0 6.5	1.0 1.0	8.0 8.0	1.0 1.0	7.5 7.0	ns
t_{PLH} t_{PHL}	Propagation Delay Bus to Bus (F648)	1.0 1.0	7.0 6.5	1.0 1.0	10.0 9.0	1.0 1.0	7.5 7.0	ns
t_{PLH} t_{PHL}	Propagation Delay SBA or SAB to A_n or B_n	2.0 2.0	7.5 7.5	2.0 2.0	10.0 10.0	2.0 2.0	9.0 9.0	ns
t_{PZH} t_{PZL}	Output Enable Time OE to A_n or B_n	2.0 2.0	7.0 7.0	2.0 2.0	9.5 9.5	2.0 2.0	8.5 8.5	ns
t_{PHZ} t_{PLZ}	Output Disable Time OE to A_n or B_n	1.0 2.0	7.0 7.0	1.0 2.0	9.5 9.5	1.0 2.0	8.5 8.5	ns
t_{PZH} t_{PZL}	Output Enable Time DIR to A_n or B_n	2.0 2.0	7.0 7.0	2.0 2.0	9.5 9.5	2.0 2.0	8.5 8.5	ns
t_{PHZ} t_{PLZ}	Output Disable Time DIR to A_n or B_n	1.0 2.0	7.0 7.0	1.0 2.0	9.5 9.5	1.0 2.0	8.5 8.5	ns

AC OPERATING REQUIREMENTS

Symbol	Parameter	54/74F		54F		74F		Unit
		$T_A = +25^\circ\text{C}$ $V_{CC} = +5.0\text{ V}$ $C_L = 50\text{ pF}$ $R_L = 500\ \Omega$		$T_A = -55^\circ\text{C to } +125^\circ\text{C}$ $V_{CC} = +5.0\text{ V } \pm 10\%$ $C_L = 50\text{ pF}$ $R_L = 500\ \Omega$		$T_A = 0^\circ\text{C to } +70^\circ\text{C}$ $V_{CC} = +5.0\text{ V } \pm 10\%$ $C_L = 50\text{ pF}$ $R_L = 500\ \Omega$		
		Min	Max	Min	Max	Min	Max	
$t_{\text{s(H)}}$ $t_{\text{s(L)}}$	Setup Time, HIGH or LOW Bus to Clock	4.0 4.0	— —	5.0 5.0	— —	5.0 5.0	— —	ns
$t_{\text{h(H)}}$ $t_{\text{h(L)}}$	Hold Time, HIGH or LOW Bus to Clock	0.0 0.0	— —	0.0 0.0	— —	0.0 0.0	— —	ns
$t_{\text{w(H)}}$ $t_{\text{w(L)}}$	Clock Pulse Width HIGH or LOW	4.0 5.0	— —	4.0 5.0	— —	4.0 5.0	— —	ns

**Case 751E-03 DW Suffix
24-Pin Plastic
SO-24 (WIDE)**

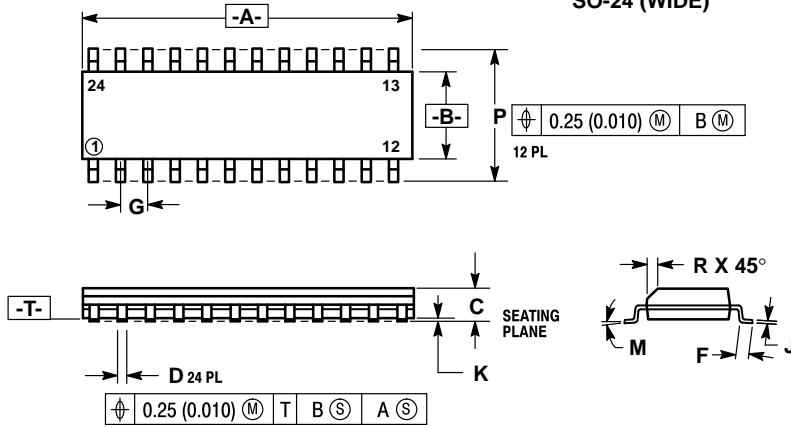

- NOTES:
1. DIMENSIONING AND TOLERANCING PER ANSI Y14.5M, 1982.
 2. CONTROLLING DIMENSION: MILLIMETER.
 3. DIMENSION A AND B DO NOT INCLUDE MOLD PROTRUSION.
 4. MAXIMUM MOLD PROTRUSION 0.15 (0.006) PER SIDE.
 5. 751E-01 AND -02 OBSOLETE, NEW STANDARD 751E-03.

DIM	MILLIMETERS		INCHES	
	MIN	MAX	MIN	MAX
A	15.25	15.54	0.601	0.612
B	7.40	7.60	0.292	0.299
C	2.35	2.65	0.093	0.104
D	0.35	0.49	0.014	0.019
F	0.41	0.90	0.016	0.035
G	1.27 BSC		0.050 BSC	
J	0.229	0.317	0.0090	0.0125
K	0.127	0.292	0.0050	0.0115
M	0°	8°	0°	8°
P	10.05	10.55	0.395	0.415
R	0.25	0.75	0.010	0.029

**Case 758-01 J Suffix
24-Pin Ceramic Dual In-Line**

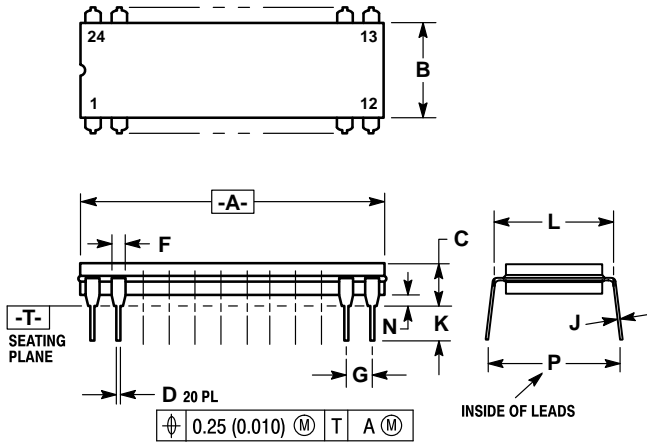

- NOTES:
1. DIMENSION L TO CENTER OF LEADS WHEN FORMED PARALLEL.
 2. DIMENSIONING AND TOLERANCING PER ANSI Y14.5, 1973.

DIM	MILLIMETERS		INCHES	
	MIN	MAX	MIN	MAX
A	31.50	32.64	1.240	1.285
B	7.24	7.75	0.285	0.305
C	3.68	4.44	0.145	0.175
D	0.38	0.53	0.015	0.021
F	1.14	1.57	0.045	0.062
G	2.54 BSC		0.100 BSC	
J	0.20	0.33	0.008	0.013
K	2.54	4.19	0.100	0.165
L	7.62	7.87	0.300	0.310
N	0.51	1.27	0.020	0.050
P	9.14	10.16	0.360	0.400

**Case 724-03 N Suffix
24-Pin Plastic**

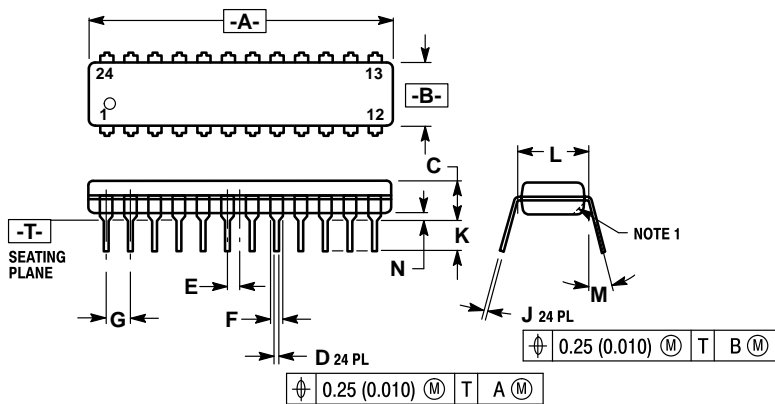

- NOTES:
1. CHAMFERED CONTOUR OPTIONAL.
 2. DIM "L" TO CENTER OF LEADS WHEN FORMED PARALLEL.
 3. DIMENSIONS AND TOLERANCES PER ANSI Y14.5M, 1982.
 4. CONTROLLING DIMENSION: INCH.

DIM	MILLIMETERS		INCHES	
	MIN	MAX	MIN	MAX
A	31.25	32.13	1.230	1.265
B	6.35	6.85	0.250	0.270
C	3.69	4.44	0.145	0.175
D	0.38	0.51	0.015	0.020
E	1.27 BSC		0.050 BSC	
F	1.02	1.52	0.040	0.060
G	2.54 BSC		0.100 BSC	
J	0.18	0.30	0.007	0.012
K	2.80	3.55	0.110	0.140
L	7.62 BSC		0.300 BSC	
M	0°	15°	0°	15°
N	0.51	1.01	0.020	0.040

Motorola reserves the right to make changes without further notice to any products herein. Motorola makes no warranty, representation or guarantee regarding the suitability of its products for any particular purpose, nor does Motorola assume any liability arising out of the application or use of any product or circuit, and specifically disclaims any and all liability, including without limitation consequential or incidental damages. "Typical" parameters can and do vary in different applications. All operating parameters, including "Typicals" must be validated for each customer application by customer's technical experts. Motorola does not convey any license under its patent rights nor the rights of others. Motorola products are not designed, intended, or authorized for use as components in systems intended for surgical implant into the body, or other applications intended to support or sustain life, or for any other application in which the failure of the Motorola product could create a situation where personal injury or death may occur. Should Buyer purchase or use Motorola products for any such unintended or unauthorized application, Buyer shall indemnify and hold Motorola and its officers, employees, subsidiaries, affiliates, and distributors harmless against all claims, costs, damages, and expenses, and reasonable attorney fees arising out of, directly or indirectly, any claim of personal injury or death associated with such unintended or unauthorized use, even if such claim alleges that Motorola was negligent regarding the design or manufacture of the part. Motorola and  are registered trademarks of Motorola, Inc. Motorola, Inc. is an Equal Opportunity/Affirmative Action Employer.

Literature Distribution Centers:

USA: Motorola Literature Distribution; P.O. Box 20912; Phoenix, Arizona 85036.

EUROPE: Motorola Ltd.; European Literature Centre; 88 Tanners Drive, Blakelands, Milton Keynes, MK14 5BP, England.

JAPAN: Nippon Motorola Ltd.; 4-32-1, Nishi-Gotanda, Shinagawa-ku, Tokyo 141, Japan.

ASIA PACIFIC: Motorola Semiconductors H.K. Ltd.; Silicon Harbour Center, No. 2 Dai King Street, Tai Po Industrial Estate, Tai Po, N.T., Hong Kong.

